



STEAM HOOD

For the capture of non grease producing equipment ie: Dishwasher machines, deck ovens & combi steamers.

As an alternative to standard an increased footprint allows a code compliant reduction in airflow.

Cavalier's Steam Hoods are measured to be site specific and achieve the best outcome for your site requirements.

Site specific drawings can be arranged. Please email your kitchen layout to info@cavaliervent.com.au to arrange a drawing.

Cooking process Type 1 & 7 as per AS1668.2-2024

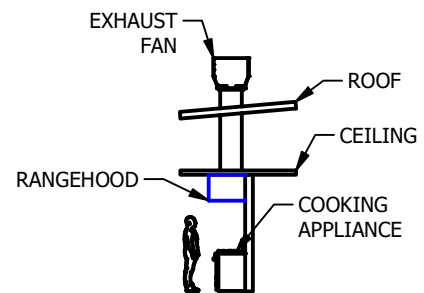
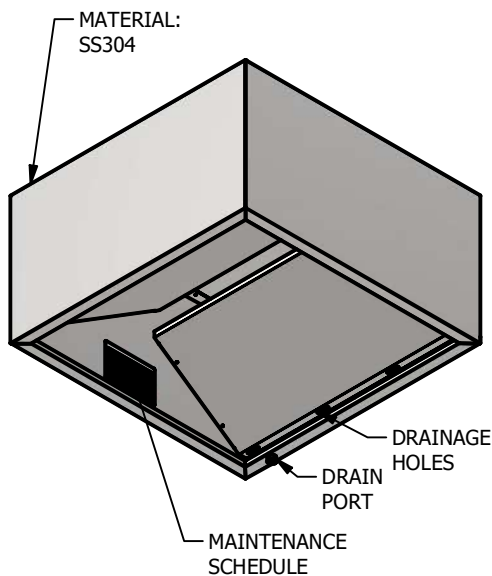

LAYOUT EXAMPLE



29 Liverpool St
Ingleburn NSW 2565
Ph: 1300 422 825

info@cavaliervent.com.au
www.cavaliervent.com.au